

SG GROUP
CONSTRUCTION & ROCK
SOLUTION
INDIAN DEALER
& TRADERS

RS03

SKID STEER LOADER



**EXCELLENT PERFORMANCE
FULLY MEET THE NEEDS OF
VARIOUS USERS.**



RS03 SKID STEER LOADER

Various accessories such as hammers, rippers, timber grabs, and rakes can be added to meet more job requirements.

Quick change can be convenient and quick to replace the auxiliary equipment.

Safe operation, can realize 360° omni-directional operation

Detachable inspection panel is convenient for inspection and inspection of sprockets and travel motors can be more rigorous.

The B&S environmentally friendly engine meets the Euro V and EPA cylinder displacement standards.

Both the wheel type and the crawler type adopt chain transmission (four driving forces), so that the transmission efficiency is higher

There are anti-skid stickers on the pedals to prevent slipping when operating the machine.



EXCELLENT BASIC PERFORMANCE



ENGINE

The design has a compact structure and powerful performance. The engine adopts B&S XR2100, which has low fuel consumption, small vibration and low noise, and has reached a high level of environmental consideration.



PETROL ENGINE — B&S XR2100

10 kw/3600rpm

[SPEED MODE ADJUSTMENT] (standard configuration)

When working, just push the pull rod, the engine speed will automatically adjust the speed, and adjust the speed gear according to the working mode to make the work more humanized



[SUPPORT ROLLER]

Both wheeled and crawler types use chain drive (four driving force), so the transmission efficiency is higher, and they can work normally in harsh environments. The left and right walking is an independent hydraulic system, and the power is more sufficient.



REPLACE ASSISTIVE DEVICEMODE (standard configuration)

When replacing auxiliary equipment such as hydraulic quick changers, breakers, and wood grabbers, you can easily replace them by pressing the button, which is convenient and quick.



MORE ACCESSORIES



Trencher



Hydraulic fork



Snowboard



Timber grapple



Digging arm



Drill rods



Forks



Rock Shovel



Breaker



Rotary drilling



snow plow



Standard bucket



Concrete mixer



Pile hammer



Fork clamp



Trench compactor

DETAILED PARAMETER CONFIGURATION

Envelope diagram

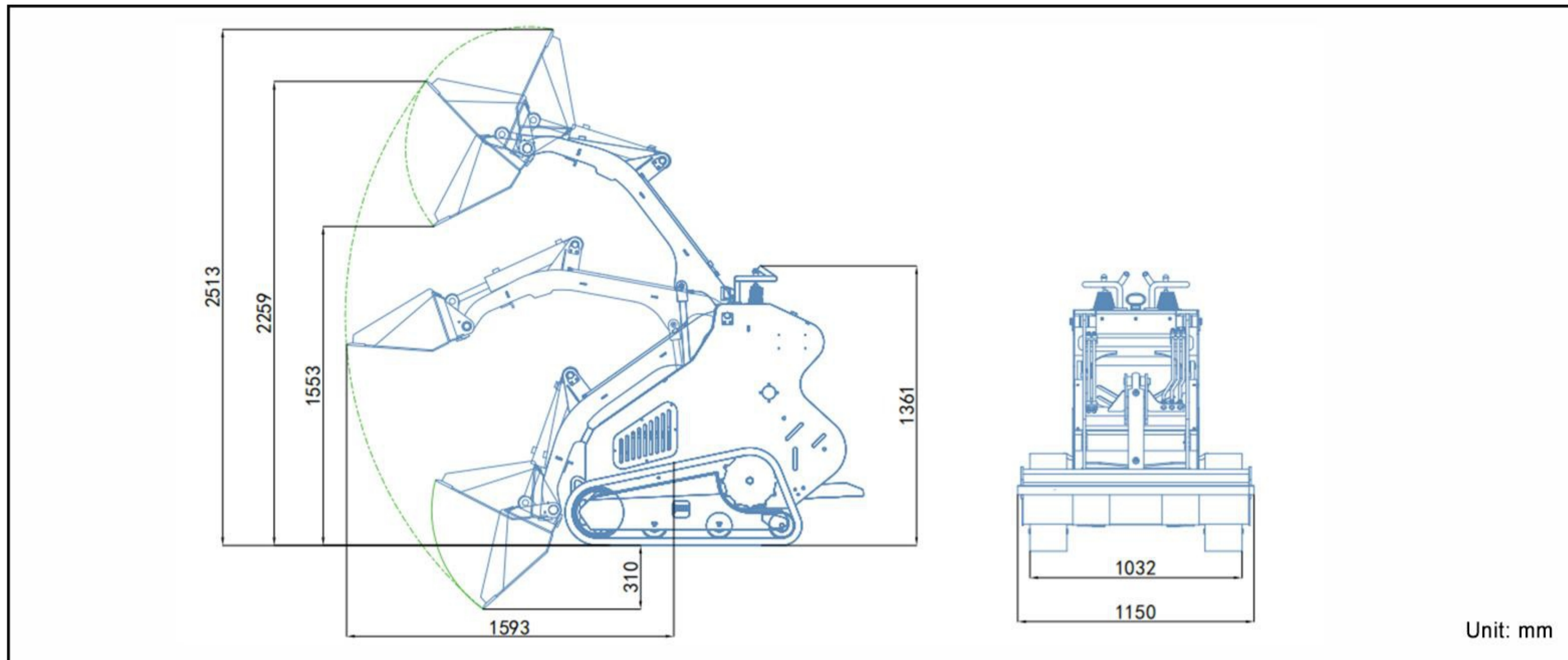

Product parameter

Basic performance parameter

Machine working weight	725kg	1595lb
Bucket capacity	0.15m³	5.3ft³
Rated load mass (safe load)	140kg	308lb
Maximum load mass	280kg	616lb
Travel speed low/high speed	0-2.5Km/h	0-1.55mph
Gradeability	25%	25%
Ground pressure	22.5Kpa	5058psi
Maximum unloading height	1553mm	61.1in
Maximum loading height	2259mm	88.9in
Maximum unloading distance	620mm	24.4in
Minimum ground clearance	129mm	5.1in

Body

Transport length - with bucket (mm)	2100mm	82.7in
Transport length - without bucket (mm)	1638mm	54.5in
Transport width (mm)	1150mm	45.3in
Transport height (mm)	1361mm	53.6in
Bucket width (mm)	1150mm	45.3in

POWERED BY B&S XR2100



Engine

Engine brand	B&S	B&S
Engine model	XR2100	XR2100
Maximum horsepower	13.6ps	13.4hp
Maximum power	10kw	10kw
Maximum speed	3600rpm	3600rpm
Displacement	0.42L	0.11gal
Number of cylinders	1	1
Cooling method	Air-cooled	Air-cooled
Engine oil change amount	1.2L	0.317gal
Fuel form	Gasoline	Gasoline
Fuel grade	92#	92#
Theoretical fuel consumption	0.8-1.2L/h	0.211-0.317gal

Hydraulic system

Main pump type/model	Gear pump PGP51044SLP
Main pump brand	Tianjin Walking
Multi-way valve brand	Tengfei
Travel hydraulic motor type	Luko BM5-250
Travel motor brand	Luko

SHOW MORE DETAILS



Oil pipeline

A metal oil pipe is used above the robotic arm, which is not easily damaged during work.



Operating handle

A single lever realizes forward, backward, steering and other actions, which is convenient for operation and has high and low speed functions.



Oil cylinder

Inverting the cylinder can effectively protect the cylinder rod from damage and extend the service life of the cylinder.



Bucket

It can be quickly disassembled and various accessories such as ripper, wood grabber, and rake can be added to meet more working requirements.

SCENARIO APPLICATION



> WE ARE S.G GROUP INDIA

we are located in Pune's Industrial Area, in India. This is a well-trusted Company that imports high-profile construction machinery and sales them. We are known and trusted for providing the customers of India the best sales of construction machines and after-sales services in India.

This is a number one company in trading of construction machinery company.

We are the Best solution for you. The company's employees are energetic and enterprising, constantly creating the legend and fame of the SG GROUP.



Pune-Mumbai Road, Mehata Chambers Kasarwadi, Pune - 411 034

E mail : info@sggrouppune@gmail.com / [sggrouppune@gmail.com](mailto:info@sggrouppune@gmail.com)

Mob : 9850100284 / 9881820284

Web : www.sggrouppune.com

GST No : 27BAEPS0979R1ZP